

SPA 16 Handsprayer

by

Levant Overseas Developments



HANDSPRAYER SPA 16

WHERE IT CAN BE USED:

-ideal for culture agricole and localised treatment of garden, orti, paddy-fields, greenhouses, vegetables, cotton, tobacco, orchards, vineyards, disinfection of buildings like warehouses, stables, public or private rooms and tropicals cultivations of small and medium size;

WHAT IT IS MEANT FOR:

-application of plant and crop protection products;

SAFETY:

-complies with latest CE regulations;
-tank with tight cover;

EASE OF USE:

-easy coupling to any operator;
-large straps ensuring ease of use;

GENERAL FEATURES:

-polyethylene tank with gauge and threaded cover with strainer;
-nypllen pump;
-spraygun with adjustable nozzle, filter and hose;
-tank basket;
-packing with carton;

VERSATILITY:

-compact shape for maneuverability operates in severe conditions;
-light and functional;
-easy-to-clean anatomical tanks with various capacities;
-various kind of nozzles, double, triple or special;

LOW MAINTENANCE COSTS:

-designed and manufactured with state-of the art technology;
-ten years experience in world markets;

WHY LOD HANDSPRAYER IS THE RIGHT CHOICE:

-modern and attractive design;
-compact profiles;
-smooth lines are gentle to plants in confined rows;
-easy to transport;
-rugged construction for severe conditions;
-high quality materials;
-competitive price.

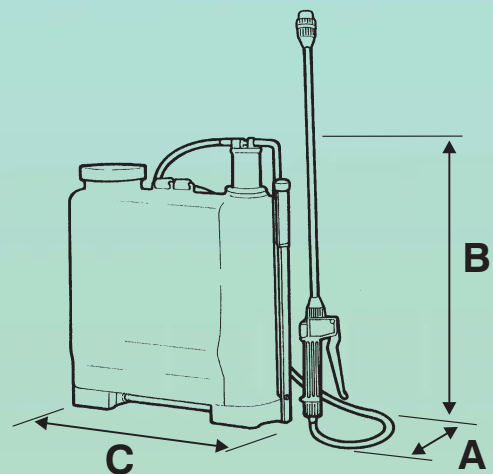

MOD.	A		B		C		Kg	Q.ty packing
	mm	inch.	mm.	inch.	mm.	inch.		
SPA 16	390	15.3	540	21.2	650	25.5	3,1	4



Levant Overseas Developments Ltd.

<http://www.levant-overseas.fr>
contact@levant-overseas.fr